

PLAN VIEW

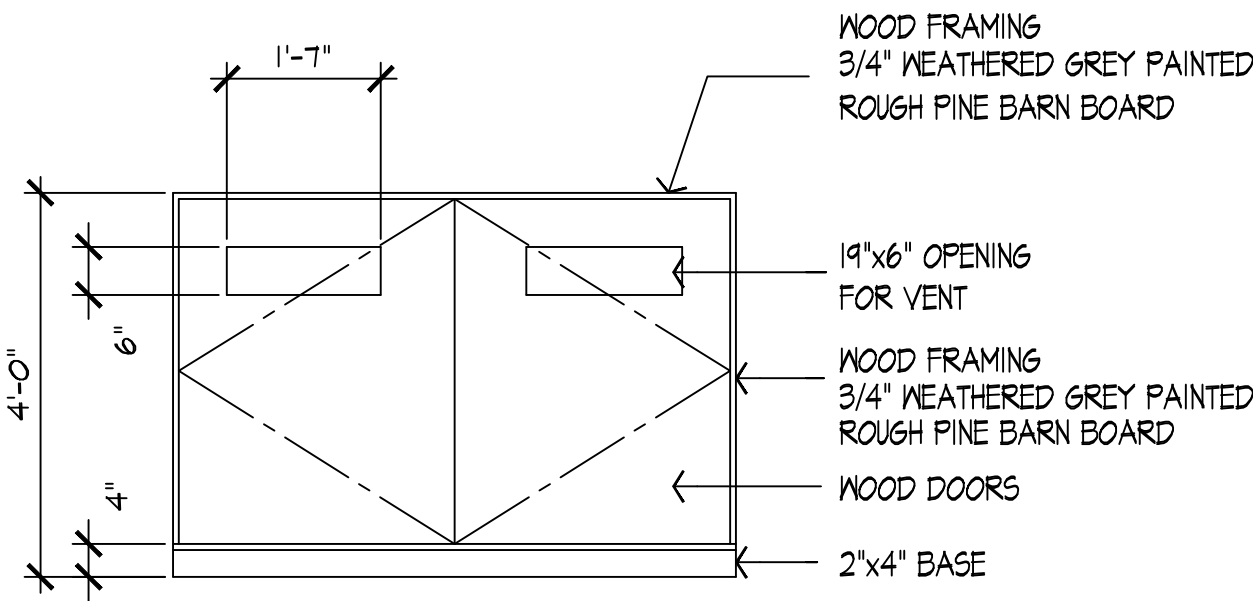

ELEVATION

GARBAGE DETAIL

SCALE = 1/2" = 1'-0"

WOOD FRAMING
3/4" WEATHERED GREY PAINTED
ROUGH PINE BARN BOARD

19"x6" OPENING
FOR VENT

WOOD FRAMING
3/4" WEATHERED GREY PAINTED
ROUGH PINE BARN BOARD

WOOD DOORS

2"x4" BASE

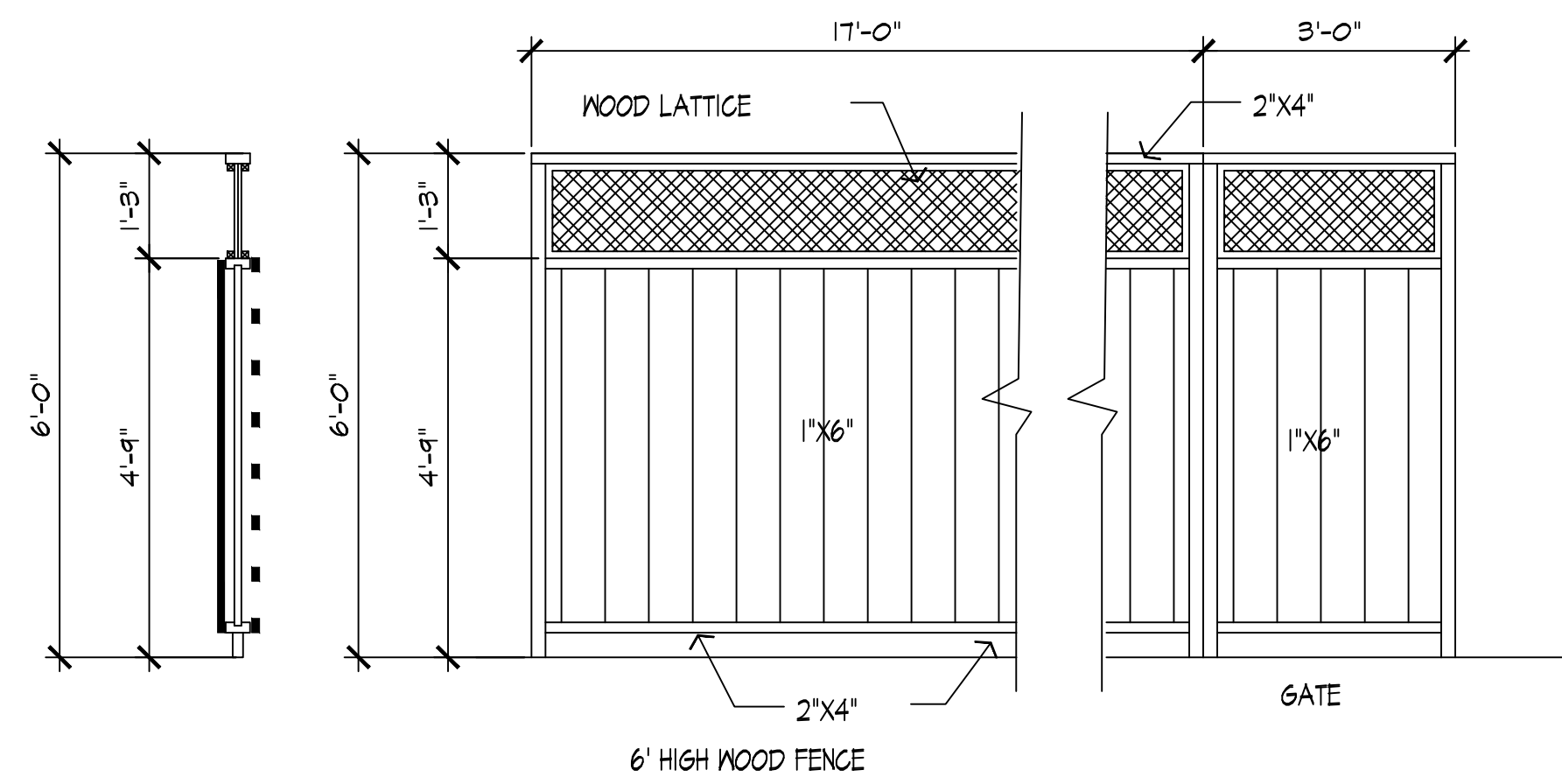

FENCE DETAIL AND SECTION

SCALE : 1/2" = 1'-0"

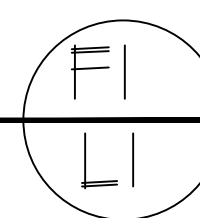

PLANT LIST					
ID	Qty	BOTANICAL NAME	COMMON NAME	SIZE	REMARKS
TREES					
SHRUBS					
BX2	4	BUXUS 'GREEN VELVET'	GREEN VELVET BOXWOOD	#5 POT	
PERENNIALS, FERNS, GROUNDCOVER					
CR	4	CROCOSMIA 'GEORGE DAVISON'	GEORGE DAVISON MONBRETIA	#1 POT	BUTTERFLY FRIENDLY
PT	26	FACHYSANDRA TERMINALIS	JAPANESE SPURGE	4" POT	
ORNAMENTAL GRASSES					
62	3	FENNISETUM ALOPECUROIDES 'HAMELN'	DWARF FOUNTAIN GRASS	#2 POT	BIRD FRIENDLY

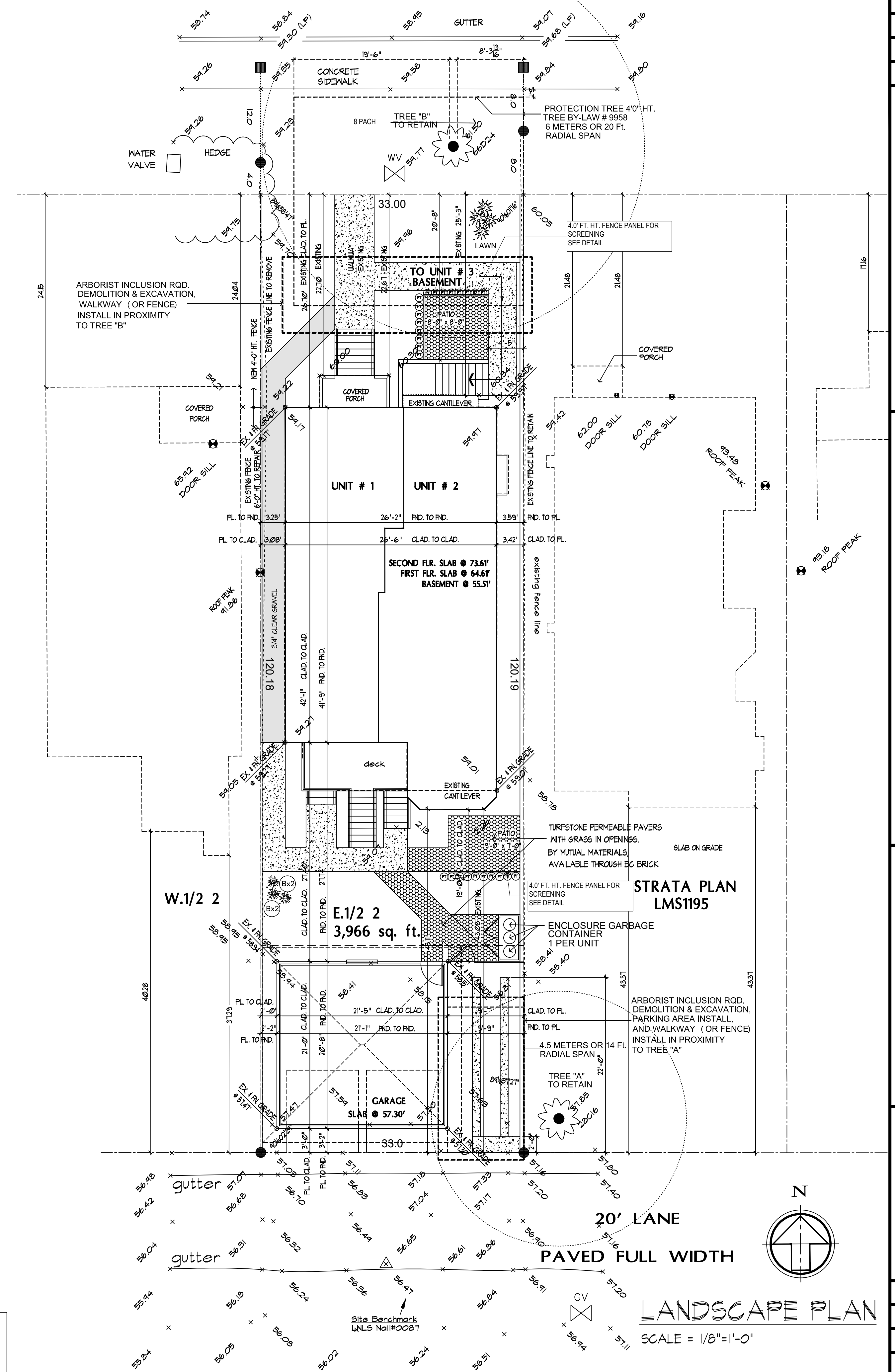

20' LANE
PAVED FULL WIDTH

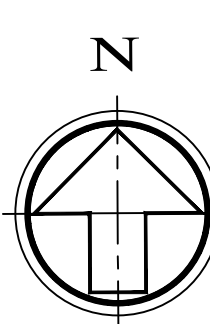

LANDSCAPE PLAN

SCALE = 1/8" = 1'-0"

APPLY VISUAL MARKERS TO THE EXTERIOR OF GLASS SURFACES
(MARKERS ON THE INTERIOR SURFACE OF GLASS ARE LESS EFFECTIVE).
GAPS BETWEEN MARKERS SHOULD BE NO GREATER THAN 5 CM VERTICALLY OR 10 CM HORIZONTALLY.
APPLIED VISUAL MARKERS ARE NOT AN OPTIMAL SOLUTION FOR ALL BUILDING TYPES.
VISIBILITY MAY BE BETTER IMPROVED WITH GREATER USE OF INTERRUPT REFLECTIVE GLASS BY
INCREASING THE DENSITY OF EXTERNAL VISUAL MARKERS INCLUDING SPANDREL PANELS AND MULLIONS

NKV Engineering & Consulting Ltd.
Structural, Geotechnical, Consulting & Inspections
1575 Kamloops Street Vancouver, BC V5K 3W1
TEL. (604) 251-6320 Email: naveem@shaw.ca

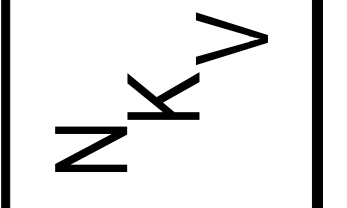

L.R. DESIGNS LTD.
15764 92nd AVENUE, SURREY B.C. V4N 2X1
TEL. (604) 727-5320 Email: lresign@shaw.ca

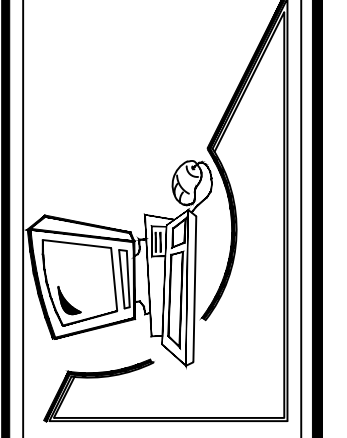

PROPOSED INTERIOR RENOVATION
RESIDENT PROJECT
OWNER: Mrs. PUNAY SHELDAN
3556 WEST 3rd AVENUE
DISTRICT OF VANCOUVER, B.C.

PROJECT: LANDSCAPE PLAN
SHEET CONTENTS:
DATE: JUNE 2018
SCALE: 1/4" = 1'-0"
DRAW: L.RIVAS
JOB:
SHEET: **L1**
OF **1**