

PLANT LIST			
601 100	PERIVIA GALICA	Shrub	#1 post heavy
602 100	PERIVIA GALICA	Shrub	#1 post heavy

Note: 1. All plant materials shall meet or exceed BCMA / BCMA standards.
2. All plant materials shall be installed within 14 days of completion.
3. All plant materials shall be installed within 14 days of completion.
4. All plant materials shall be installed within 14 days of completion.

LANDSCAPE	
100	BRUSH-FINISH CONCRETE
101	LOOSE GRAVEL
102	PAVING STONE

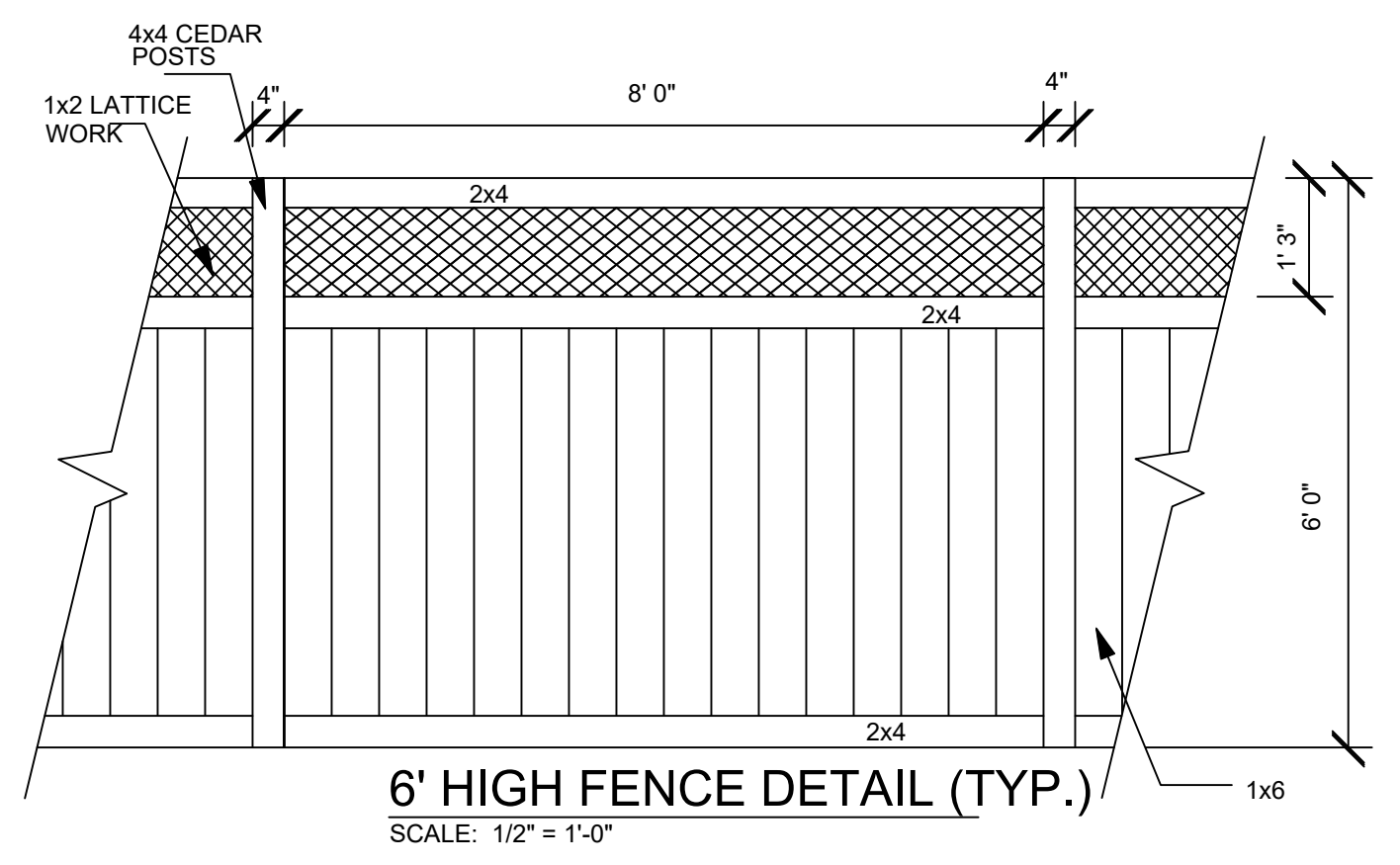
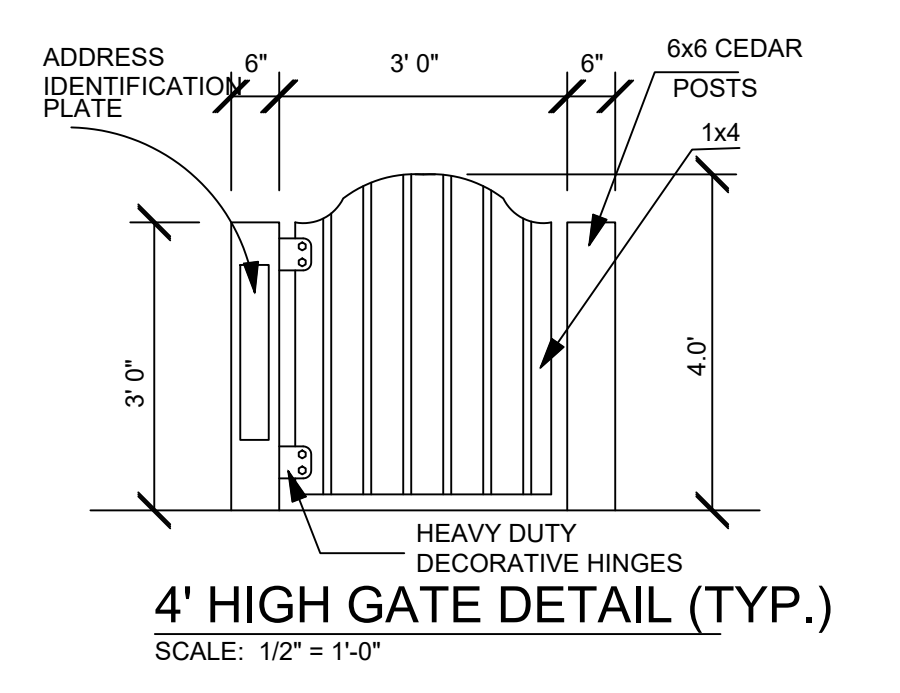
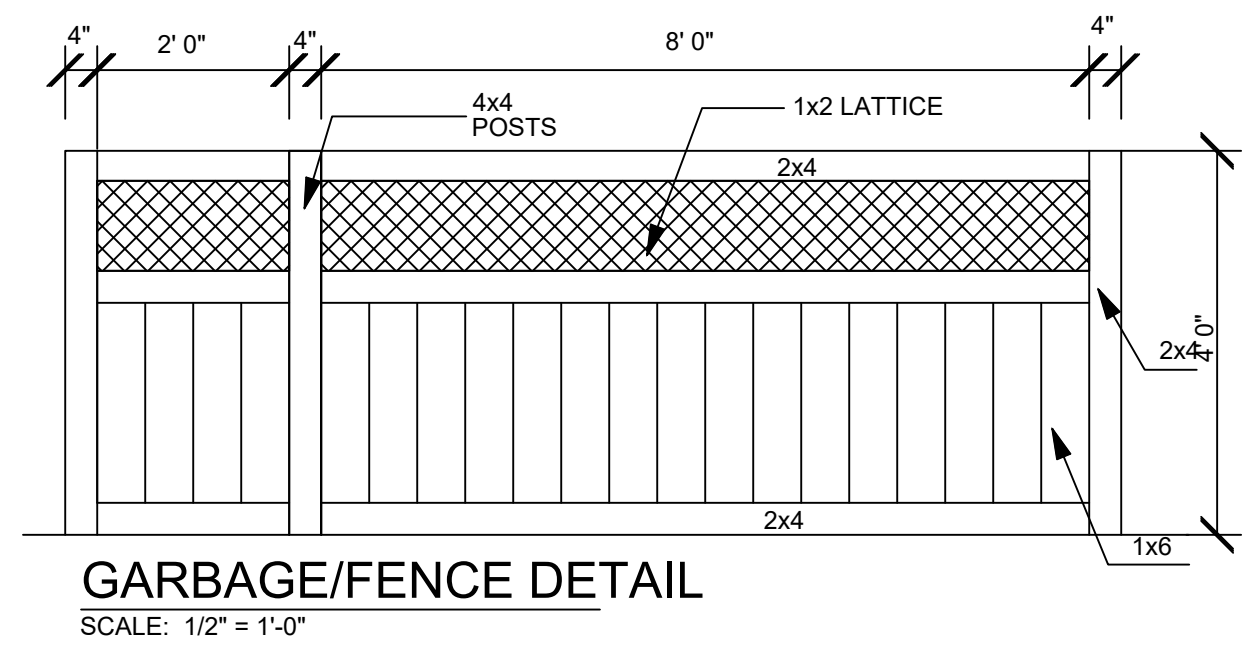
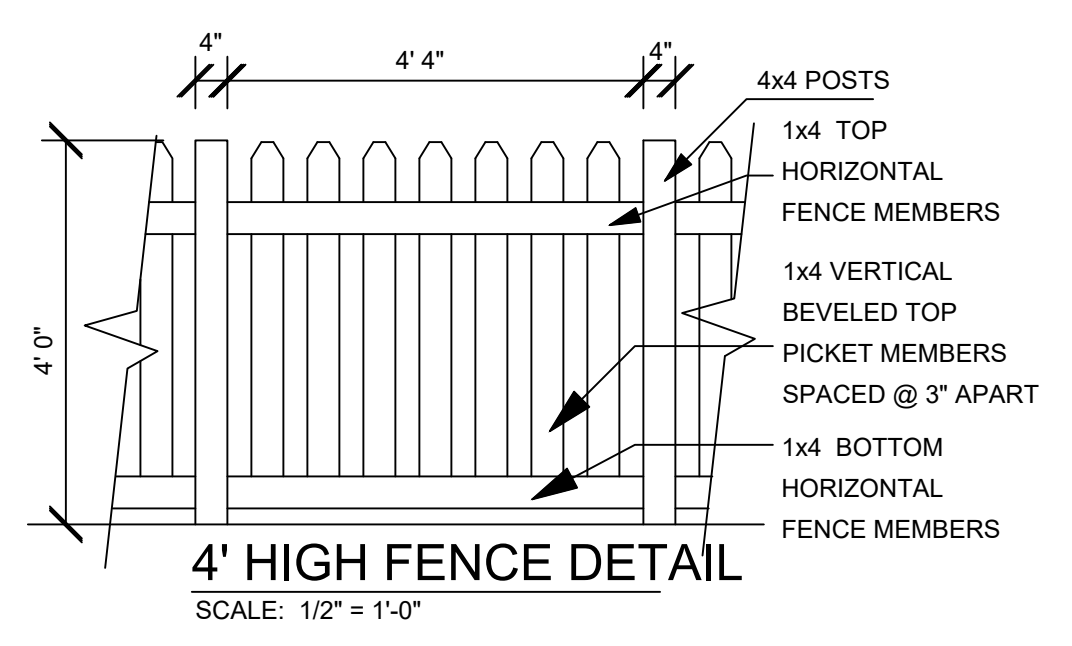
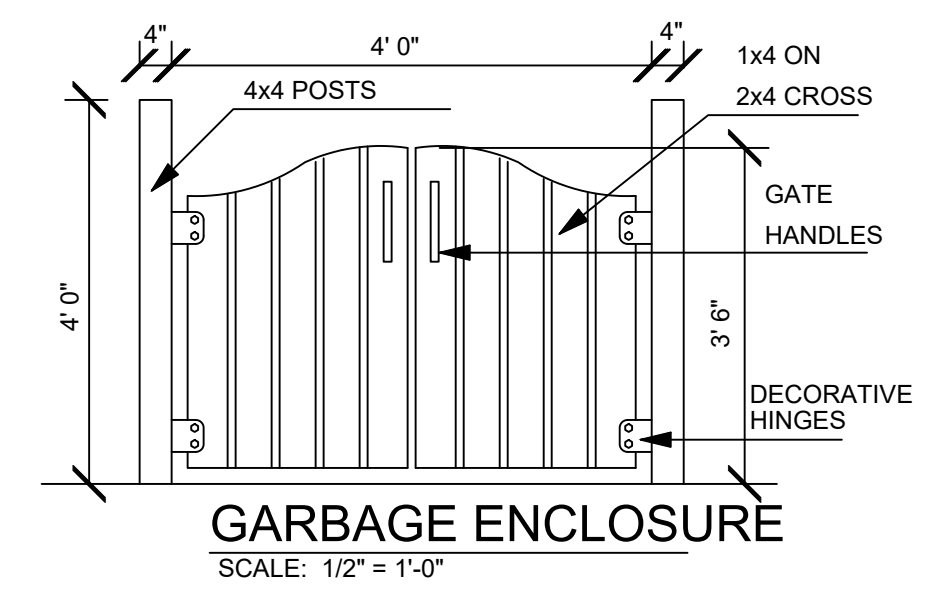

PROPOSED SFD ON 2396 E 38 AVE VANCOUVER, BC

Raj Home Design
Raj Home Design
6225 Fraser Street
Vancouver, B.C. V5R 2T6
www.rajhomedesign.com

Copyright Reserved. All drawings contents here of are property of Raj Home Design and can not be replicated without their knowledge and written consent. Designer is the responsibility of the contractor for check and complete the drawings and information prior to commencement of work and to report any omissions or discrepancies to the Designer.

DESIGNER	B SINGH
PHONE NO.	604 441 1910
ISSUE DATE	05/23/18
SCALE	AS NOTED
APPROVED BY	B SINGH
CHECKED BY	B SINGH
DRAWN BY	RAJ
REV. NUMBER	

DRAWING NAME:
LANDSCAPE DESIGN

DRAWING NO.:
A10